

## MICON 5 S, SMT Standard, 3,6 ± 0,72 N, 1 S



### Beschreibung

Die MICON 5 Kurzhubtaster sind extrem schaltsichere Bauelemente mit sehr geringem Platzbedarf. Sie können einzeln, in Reihen oder als Tastenfelder angeordnet werden. Für den Einsatz unter Folie empfehlen wir die MICON 5-Taster mit Stößeln zu kombinieren. Die Eigenschaften auf einen Blick:

- › Geeignet für die wichtigsten Lötverfahren
- › Wellen-Lötbad für THT-Versionen
- › Reflow-Löten für SMT-Versionen
- › Dampfphasen-Löten für SMT-Versionen
- › Handlötung
- › Verarbeitung der SMT-Ausführung mit SMT-Bestückungsautomaten
- › IMDS-Eintrag
  
- › Verpackung im Blistergurt, Spule mit 2.100 Stück
- › Vorschlag für Schablonendruck: 150 µm-Schablone mit 10% Pad-Verkleinerung auf Fläche



### Technische Daten

#### › Allgemein

Arbeitstemperatur, min.	-40 °C
Arbeitstemperatur, max.	125 °C
Lagertemperatur, min.	-40 °C
Lagertemperatur, max.	90 °C
beleuchtbar	nein
Lötverfahren	Reflow
Lötwärmebeständigkeit nach Norm	DIN EN 60068-2-58 DIN EN 61760-1
Verpackung	Blister
Verpackungseinheit	2.100 Stück
Nettogewicht	0,2 g
Lebensdauer	250.000 Zyklen
B10	325.000 Zyklen
Schutzart frontseitig gem. ISO 20653	IP67 (IP6K7)
Schutzart rückseitig gem. ISO 20653	IP67 (IP6K7)
MSL Moisture Sensitivity Level	1
Schockfestigkeit gem. Norm IEC 60068-2-27	100 g bei 6 ms Amplitude halbsinusförmig
Schwingbeständigkeit gem. Norm IEC 60068-2-6	5 g bei 10...500 Hz

#### Direkte Links

- › [RAFI eCatalog](#)

Mindestbestellmenge (MOQ)	2.100 Stück
RoHS konform	ja
REACH konform	ja
Produktcode	ZS
Ursprungsland	DE
<b>&gt; Einbaumaße</b>	
Außenmaß Länge	6,4 ± 0.1 mm
Außenmaß Breite	5,1 ± 0.1 mm
Einbauhöhe	3,85 ± 0.1 mm
Raster, min.	6 x 7.8 mm
<b>&gt; Mechanische Kennwerte</b>	
Anschluss rückseitig	SMT
Betätigungsfunktion	tastend
Betätigungskraft, max.	6 N
Betätigungskraft, min.	3,6 ± 0.72 N
Kontaktfunktion	1 S
Kontaktsystem	Sprungkontakt SPST - Single Pole Single Throw
Kontaktwerkstoff	Gold
Lötbarkeit	Ja
Prellzeit bei 10 mm/s	<5 ms
Schaltweg	0,8 ± 0.15 mm
<b>&gt; Elektrische Kennwerte</b>	
Schaltspannung, min.	0,02 V
Schaltspannung, max.	35 V
Spannungsfestigkeit	250 V
Schaltstrom, min.	0,00001 A
Schaltstrom, max.	0,1 A
Schaltleistung, max.	1 W

## Zeichnungen

### Maß-Zeichnungen

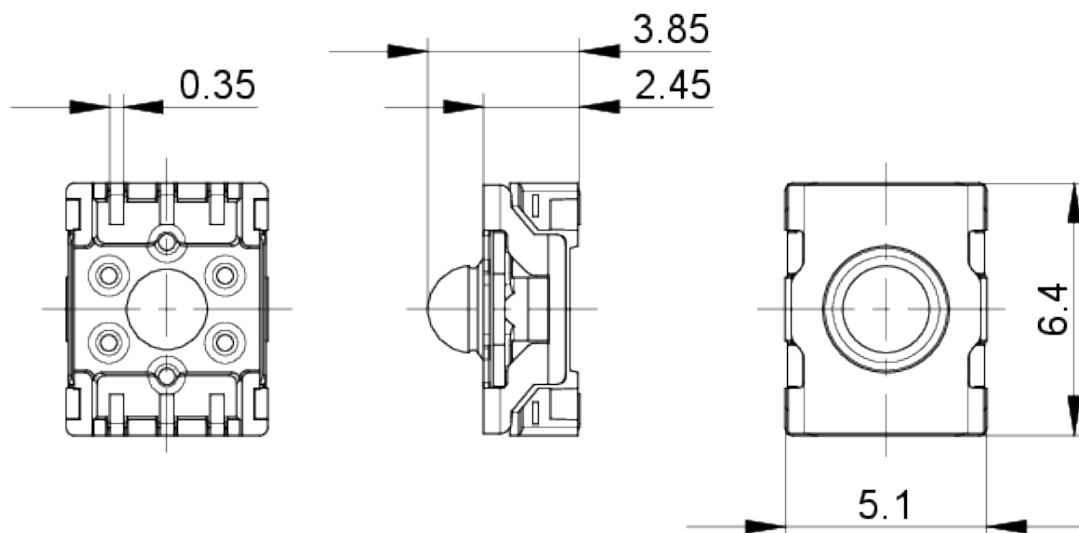

### System-Zeichnung

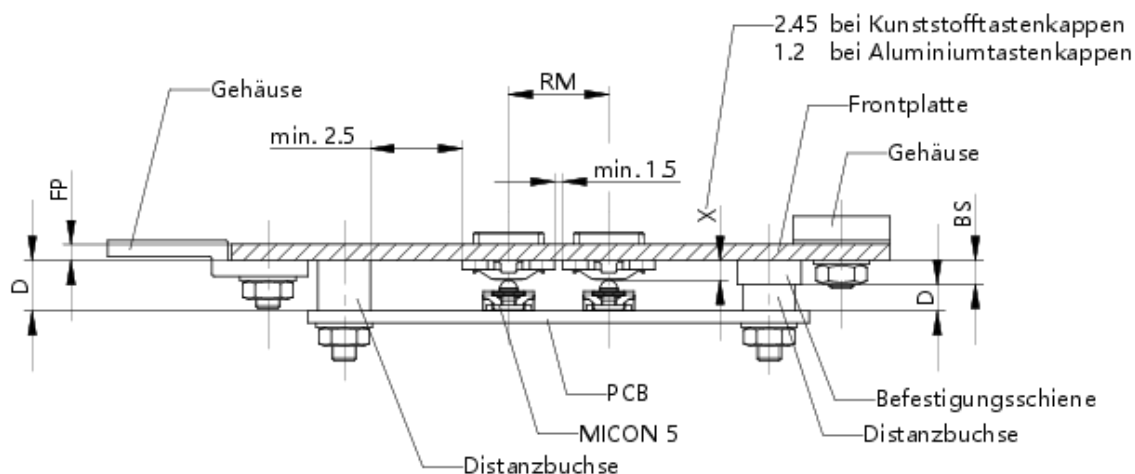

**Leiterplatten-Zeichnung**

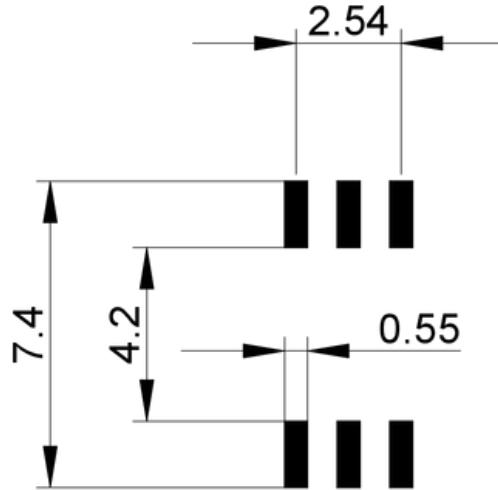

**Leiterplatten-Zeichnung**

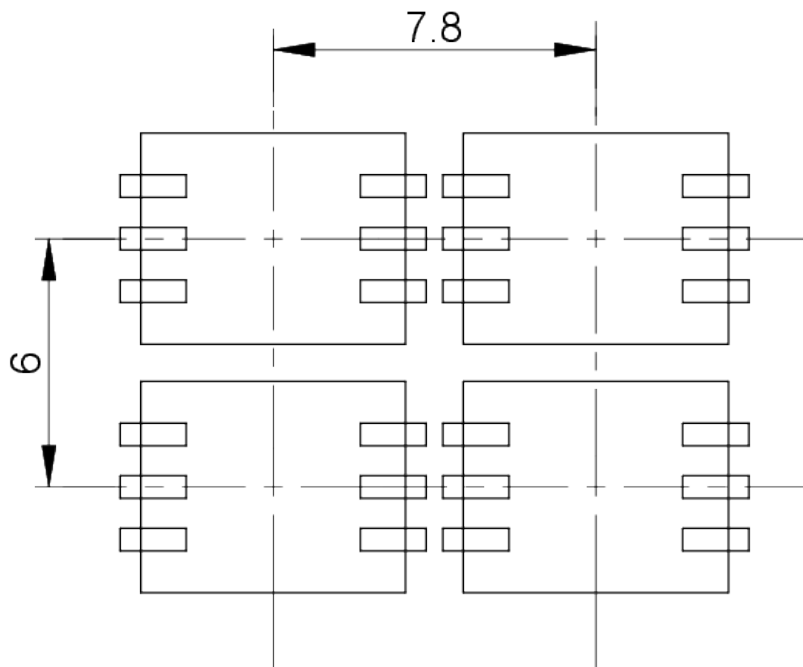

MICON 5 SMT

Schaltschema-Zeichnung

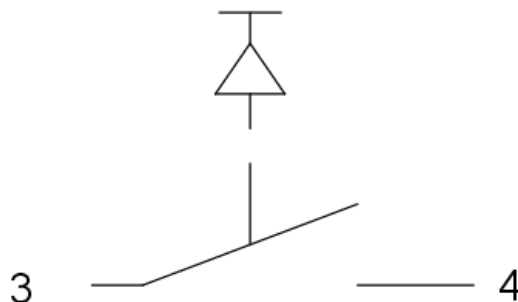

Schaltzeichen nach IEC 617

Produktkennzeichnung-Zeichnung

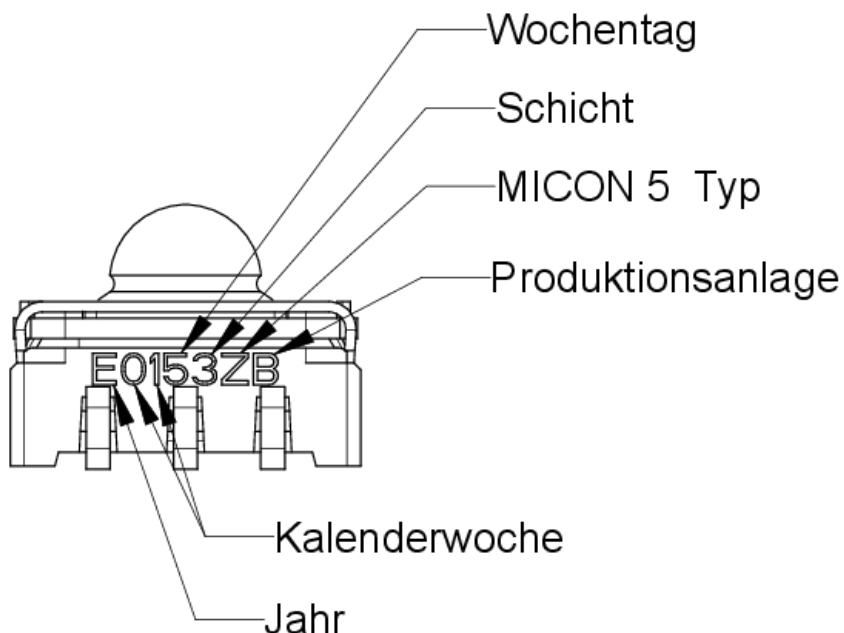

Verpackungs-Zeichnung

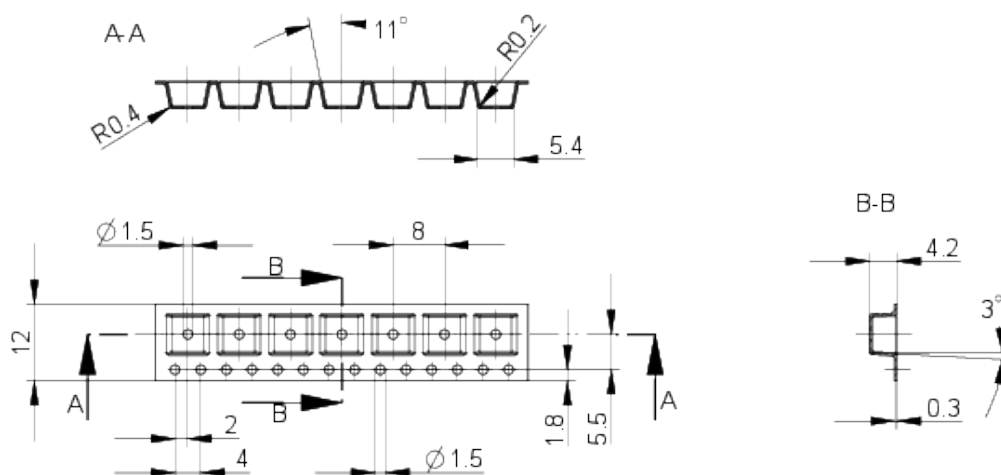

Verpackungs-Zeichnung

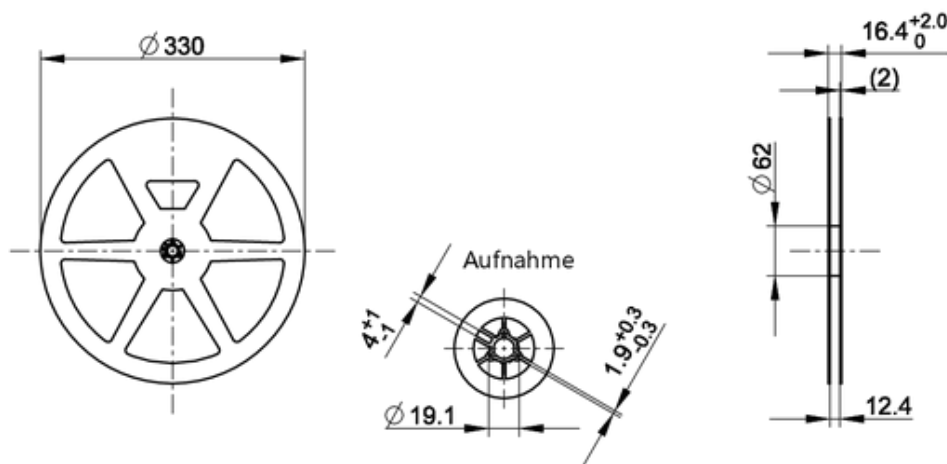

## Montage

### RAFI soldering profile for ROHS compliant reflow components



Publication date: October 7, 2021

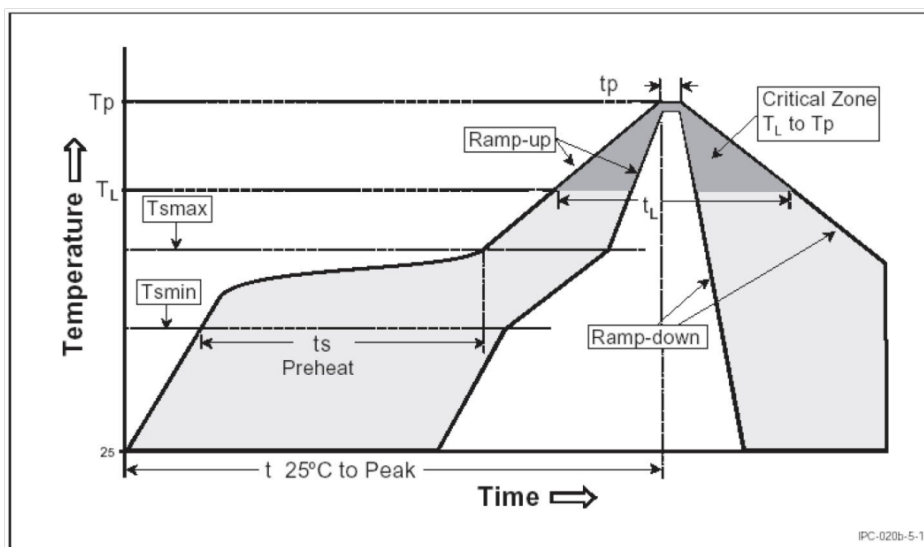

Parameter	RAFI values
Gradient ( $T_L$ to $T_P$ )	max. 3°C / s
<b>Preheating zone</b>	
Minimum temperature ( $T_{smin}$ )	150°C
Maximum temperature ( $T_{smax}$ )	200°C
Time (from min. to max.) ( $t_s$ )	60 - 120 s
Gradient ( $T_{smax}$ to $T_L$ )	max. 3°C / s
Time over melting temperature ( $T_L$ ) time ( $t_L$ )	217°C 60 - 150 s
Peak temperature ( $T_P$ )	max. 260°C (+0°C)
Time within peak temperature - 5°C ( $t_p$ )	20-40 s
Gradient ramp down	max. 6°C / s
Time difference from 25°C to peak temperature	max. 8 minutes

The reflow soldering profile is based on the definition of Jecdec J-STD-020D.

The information in this sheet only contains general descriptions and / or performance features, which may not apply precisely as described to the respective application, and which may change due to further product enhancements. The technical data, illustrations and other information about our products are the mere results of individual technical testing. These descriptions and other product features are only binding if they expressly agreed upon at the time of the conclusion of a binding contract. In all other cases, we reserve the right to make technical changes as well as changes of availability. Pictures and other graphic illustrations are approximations only. All product names may be trademarks or brand names of the RAFI Group or any other sub-supplier of RAFI. The use of such by any third parties for their own purposes may infringe the rights of the respective entity holding those rights. Subject to change and errors excepted. Details about delivery times and availability are noncommittal and have no legal force.

RAFI GmbH & Co. KG  
 Ravensburger Str. 128-134, 88276 Berg / Ravensburg  
 GERMANY – www.rafi-group.com

page 1 of 1

## Media Robust Electronics



Publication date: February 13, 2025

## MICON 5 S, SL and SAFETY

Valid for all variants MICON 5 S 1.14.005., MICON 5 SL 1.14.105. and MICON 5 SAFETY 1.14.205.

### Recommended potting compounds

WEVO-CHEMIE GmbH

WEVOPUR 7210 FL/WEVONAT 507

#### Important note

Maximum potting height B must not be exceeded.

### Recommended circuit board protection

Lackwerke Peters GmbH & Co.KG

combination of high-viscosity (HT-T)  
and low-viscosity coating from the  
ELPEGUARD® SL 1307 family

Lackwerke Peters GmbH & Co.KG

ELPEGUARD® SL 1800

#### Important note

The conformal coating of our tactile switches must be tested in the final application. Coating that enters the tactile switch does not harden directly, so that any resulting malfunction can only be detected later.

If the tactile switch is completely coated, the coating may peel off the elastomer of the tactile switch during the first few actuations. Press the tactile switch only after the coating has hardened.

We recommend leaving out the elastomer area when coating to prevent detachment.

#### General remark

The suitability and use of the recommended media for potting, conformal coating and nano-coating must be qualified and approved in the final application.

The potting, conformal coating and nano-coating must be used in accordance with the manufacturer's technical data sheet.

Actuation of the tactile switch only after the potting compound, conformal coating and nano coating has completely hardened.

Other potting compounds and processes for printed circuit board protection on request.

The information in this sheet only contains general descriptions and / or performance features, which may not apply precisely as described to the respective application, and which may change due to further product enhancements. The technical data, illustrations and other information about our products are the mere results of individual technical testing. These descriptions and other product features are only binding if they expressly agreed upon at the time of the conclusion of a binding contract. In all other cases, we reserve the right to make technical changes as well as changes of availability. Pictures and other graphic illustrations are approximations only. All product names may be trademarks or brand names of the RAFI Group or any other sub-supplier of RAFI. The use of such by any third parties for their own purposes may infringe the rights of the respective entity holding those rights. Subject to change and errors excepted. Details about delivery times and availability are noncommittal and have no legal force.

#### RAFI GmbH & Co. KG

A RAFI Group company  
Ravensburger Straße 128-134, 88276 Berg, Germany  
P +49 751 89-0, F +49 751 89-1300  
info.headquarters@rafi-group.com, rafi-group.com

page 1 of 1